

SAFETY VALVE HSV

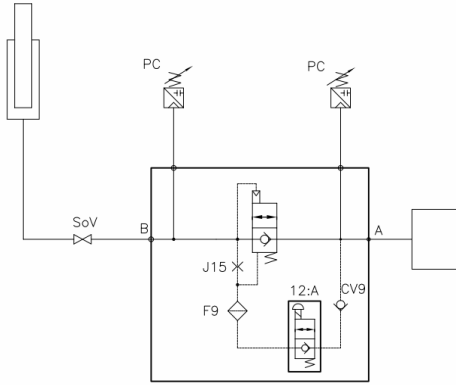

The Safety Valve HSV is an electrically pilot operated check valve for hydraulic lifts. Installed between the cylinder and the control valve as close as possible to the lift valve. It enables the oil flow from the lift valve A to the cylinder B during travel UP, and enables the flow in opposite direction (from B to A) until the pilot valve 12:A is energized.

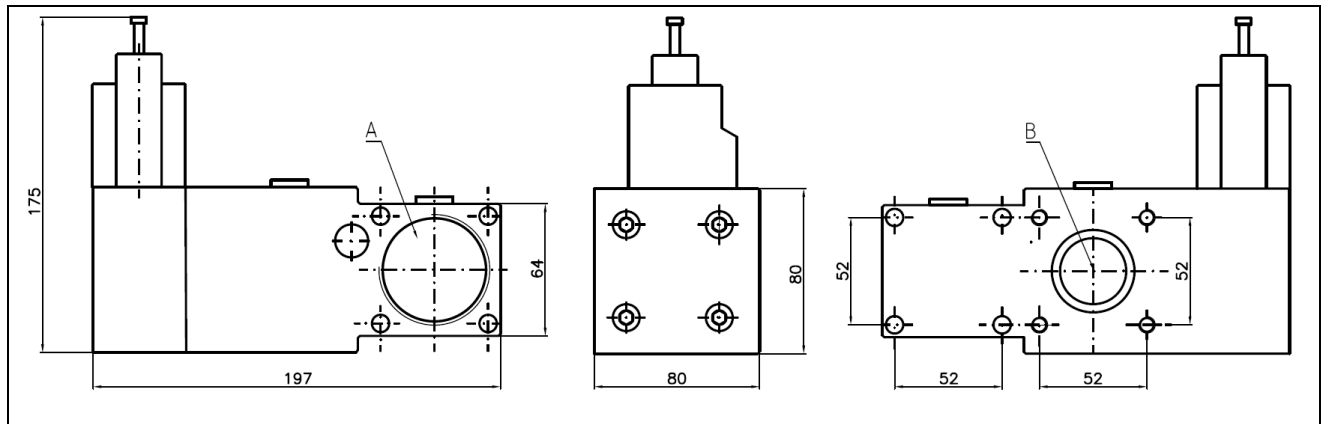

Figure 1

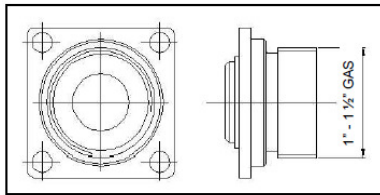

Figure 2

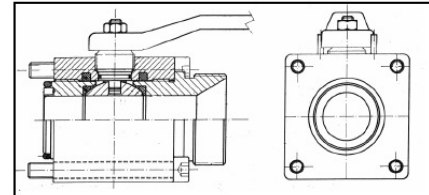

Figure 3

Type	Port A		Port B
	H300	Other Control Valve	For any Control Valve
HSV-150	Flanged with 4 screws	Female Threaded 1 1/4" BSP	<ul style="list-style-type: none"> Flanged shut off valve 1", -1 1/4", 1 1/2" Gas (Fig3) Male Threaded flange fitting 1", -1 1/4", 1 1/2" Gas (Fig 2)
HSV-440	Flanged with 4 screws	Female Threaded 1 1/4" BSP	<ul style="list-style-type: none"> Flanged shut off valve 1", -1 1/4", 1 1/2" Gas (Fig3) Male Threaded flange fitting 1", -1 1/4", 1 1/2" Gas (Fig 2)

Working Limits	HSV-150	HSV -440
Flow range [L/min]	50 ÷ 150	150 ÷ 440
Operating pressure [bar]	10 ÷ 50	10 ÷ 50
Pressure drop A to B [bar]	< 1	< 3,7
Pressure drop B to A [bar]	< 1,5	< 5
Viscosity range [cSt]	25-200	25-200
Temperature [°C] *	+ 5°C ÷ + 60°C	+ 5°C ÷ + 60°C
Permissible fluids	Hydraulic Oil	Hydraulic Oil

* To comply with the working limits of the Safety Valve HSV select an appropriate oil type for the working temperatures according to page HL 04.05 of "HL GENERAL CATALOGUE".

The Safety Valve **HSV** is suitable for all power units that complies the **EN 81.2** code

Control Panel

State of the lift	State of the solenoid valve			Remarks
	Must be energised	Must be de-energised	Arbitrary	
Travel UP with door closed			X	No influence of the Safety Valve during travel UP
Travel DOWN with door closed	X			
Standstill with door open	X			For load pressure sensing and releveiling
Standstill with door closed, DOWN travel is starting immediately	X			The Safety Valve must be energized at least 300 ms before travel starts, otherwise the travel control of the lift valve can be affected negatively
Long standstill period with door closed		X		To increase the Energy Saving
Unintended travel up with door open			X	No influence of the Safety Valve during travel uptravel, lift must be stopped by the disconnection of the motors contactors
Unintended travel downwards with door open		X		Interruption of the current to the solenoid of the Safety Valve with dedicated and certified switch when the unlocking zone is left(emergency stop)
Hand pump operation			X	No influence of the Safety Valve during the travel UP
Electrical Emergency lowering	X			Through the optionally available emergency power winding of the Safety Valve
Manual Emergency lowering			X	Through manual release of the Safety Valve

Sequence of signals at normal operation (example with H300 control valve)

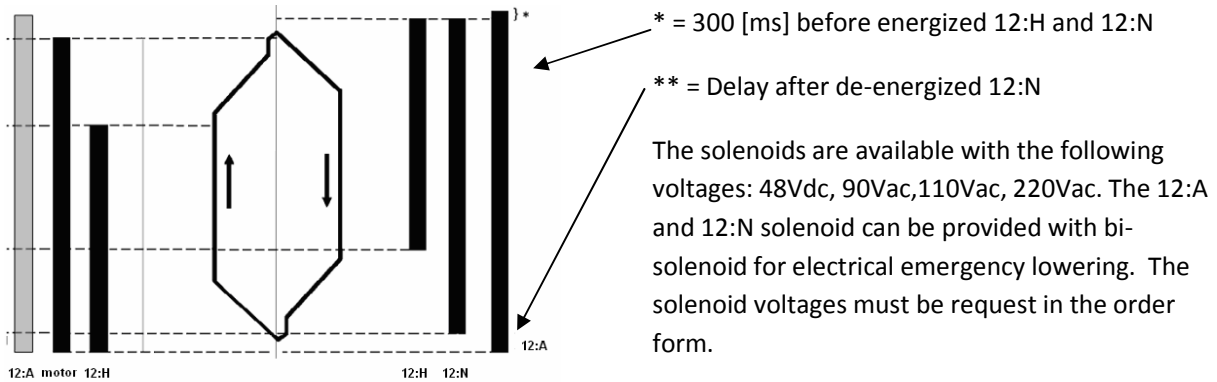

Sequence of signals at emergency stop

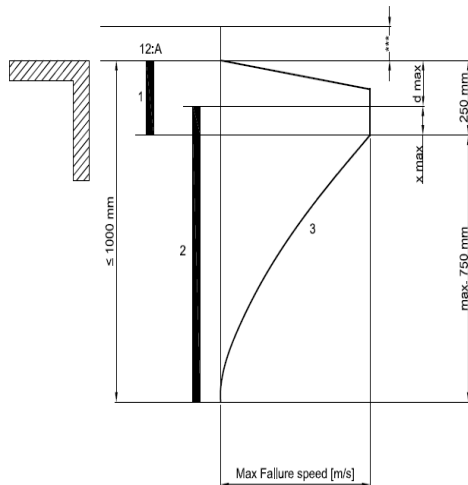

The figure shows the diagram of movement and commutation in case of emergency operation. The speed profile could change considerably in presence of unintended car movement. The worst case in with the HSV must stop the lift is max car speed plus 0,3 m/s. For higher speed the lift must be stopped by the pipe rupture valve. You can see that the 12:A solenoid must be de-energized no later than when the car has left the floor of landing, to comply the minimum distance required by the code to arrest the lift, according to the established deceleration limit. The unintended car movement is individuated by a detector positioned into the lift shaft near the unlocking doors zone. The detector information is sent to the control panel that, through a dedicated and certified A3 device switch, cut the electrical

supply to the 12:A solenoid.

Numer	Description
1	HSV solenoid is energized
2	Shaft switch has tripped
3	Travel curve at unintended DOWN travel with maximum acceleration
***	300 ms before the DOWN travel commands is present

Due to the fact that the Safety Valve HSV and the device switch of the control panel are not working simultaneously with the normal lift's operation, **the system does not require monitoring.**

Detector

EN81-2:2010, paragraph 9.13.5 prescribes that the lift that moves unintentionally DOWN with open doors shall be stopped so that:

the distance between the floor of the car and the floor of the landing will not exceed 1200 mm.

The free distance between the car door lintel and the landing floor shall not be less than 1000 mm.

Both requirements must be fulfilled simultaneously. In order to exploit both these criteria simultaneously the clearance height of the open door must to be at minimum 2200 mm, but due to the fact that clearance height of many car doors is only 2000 mm, the maximum permitted distance between car floor and the floor landing is reduced to 1000 mm.

The worst case in with the HSV must stop the lift is max car speed plus 0,3 m/s. For higher speed the lift must be stopped by the pipe rupture valve. In the worst case this speed is 1,3 m/s.

The Safety Valve HSV has been designed so that, considering a speed of v_{max} of 1,3 m/s, maximum load and unfavourable oil conditions, the lift will stop within 750 mm from the de-energising of the safety valve HSV solenoid 12:A. That means that the safety valve HSV solenoid must be de-energized when the lift has travelled not more than:

$$1000 \text{ mm} - 750 \text{ mm} = 250 \text{ mm}$$

The signal processing time t , that it takes from the lift control to detect the travel with open door until the safety valve HSV solenoid is de-energized gives the distance travelled during signal processing x_{max} according to the formula:

$$x_{max} = v_{max} * t$$

The maximum permitted distance d_{max} between the shaft switch and the landing position is:

$$d_{max} = 250 \text{ mm} - v_{max} * t$$

